

VALIANT COMMUNICATIONS LIMITED



VCL-MX Version 6 80 E1, 160Mbps Voice & Data Multiplexer

System Guide

INDIA

Valiant Communications Limited

71/1, Shivaji Marg, New Delhi - 110015, India
Phone: +91-11 4105 5601, +91-11 4105 5602,
+91-11 4105 5603, +91-11 2592 8415,
Fax: +91-11 4105 5604, +91-11 2543 4300
E-mail: getinfo@valiantcom.com
Website: <http://www.valiantcom.com>

U.S.A.

Valcomm Technologies Inc.

4000 Ponce de Leon, Suite 470
Coral Gables, FL 33146
United States of America
E-mail: fl@valiantcom.com
Website: <http://www.valiantcom.com>

U.K.

Valiant Communications (UK) Ltd

1, Acton Hill Mews, 310-328 Uxbridge Road,
London W3 9QN
United Kingdom
E-mail: uk@valiantcom.com
Website: <http://www.valiantcom.com>

Warranty

This Valiant product is warranted against defects in material and workmanship for a period of one year from the date of shipment. During the warranty period, Valiant will, at its discretion, either repair or replace products, which prove to be defective. For warranty service or repair, this product must be returned to a service facility designated by Valiant. The buyer shall prepay shipping charges to Valiant and the company shall pay shipping charges to return the product to the buyer. However, the buyer shall pay all the shipping charges, duties and taxes for products returned to Valiant from another country.

Limitation of Warranty

The foregoing warranty shall not apply to defects resulting from improper or inadequate maintenance by the buyer. The buyer-supplied firmware or interfacing, unauthorized modification or misuse, operation outside of the environmental specifications for the product or improper site preparation or maintenance.

Exclusive Remedies

The remedies provided herein are the buyer's sole and exclusive remedies. Valiant shall not be liable for any direct, indirect, special, incidental or consequential damages, whether based on contract or any legal theory.

Notice

This manual contains information that is proprietary to Valiant Communications Limited. No part of this publication may be reproduced in any form whatsoever without prior written approval by Valiant Communications Limited.

Safety Warnings



The exclamation point within a triangle is intended to warn the operator or service personnel of operation and maintenance factors relating to the product and its operating environment, which could pose a safety hazard.

Always observe standard safety precautions during installation, operation and maintenance of this product. Only qualified and authorized service personnel should carry out adjustment, maintenance or repairs to this instrument. No adjustment, maintenance or repairs should be performed by either the operator or the user.

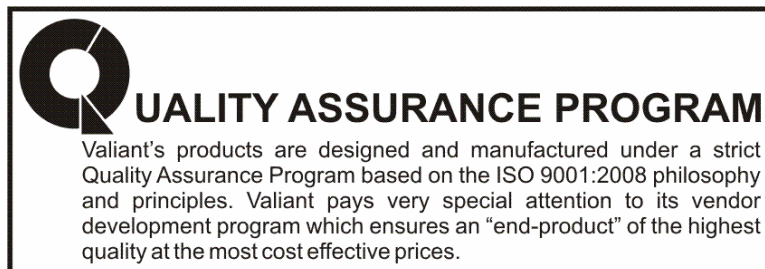

Index

S. No.	Particulars	Page No.
1	Foreword	4
2	Product Overview	5
3	Key Features	6
4	Additional Features	6
5	Highlights	7
6	Security and Password Features	7
7	Transmission Mediums	7
8	Multi-service platform	8
9	Configuration and Flexibility	8
10	Synchronization	8
11	Application of VCL-MX	9
12	System Overview and Architectural Details	9
13	Safety: Laser protection	9
14	Front View	10
15	Back View	11
16	Voice Interfaces	11
17	Data Interfaces	12
18	Chassis / System Backplane	12
19	System Management	12
20	Technical Specifications	13
21	Protection	22
22	Management Interfaces	22
23	Power Supply	22
24	Power Consumption	23
25	Environmental	23
26	Dimensions	23
27	Application Diagrams	24
28	Ordering Information	30
29	Support	35

Foreword

The VCL-MX Version 6 - 80 E1, 160Mbps Multiplexer is a compact, carrier class and cost-effective bandwidth provisioning equipment designed to manage and deliver services from the optical core to the access.

This system guide presents the technical specifications along with the functions and features of the product. It gives a brief description of the hardware and software associated with the VCL-MX Version 6 - 80 E1, 160Mbps Multiplexer. This user guide also gives an overview of the various applications in which VCL-MX Version 6 - 80 E1, 160Mbps Multiplexer can be used. These are explained with the use of application diagrams. These application diagrams are useful for the Network planning and design engineers.

Product Overview

VCL-MX Version 6 – 80 E1 Multiplexer may be used for inter-connecting legacy voice and data networks, provisioning and managing bandwidth on a E1 channelized level as well as 64Kbps, DS-0 time-slot level and as a digital-access cross-connect equipment. Due to the changing traffic patterns, there is a need to support multiple services from the same equipment like integrated data transport, better network management etc. This necessitated evolution to next generation E1 Multiplexer.



Redundant control card and power supply options make it an ideal choice for network service providers seeking to integrate and provide legacy and the next generation services from a single platform.

Next generation E1 Multiplexer has emerged as one of the most economical and technologically viable solutions for transmitting both voice and data over carrier networks. This technology offers savings on investments/power and space to service providers.

Valiant Communications Limited provides efficient solutions in this field using the E1 Multiplexer series products. E1 Multiplexer provides a full range of solutions in this evolving field of next generation telecom solutions. E1 Multiplexer family provides the unique advantage of carrying both data and voice over PDH. In addition to being affordable, these products have built-in modularity, which allow easy upgradeability. This upgradeability feature allows the customer to evolve in a “build-as-you-grow” concept. Along with the Valiant as Network Management solution the E1 Multiplexer family provides the following features:

- Easy network manageability
- Lower cost per line
- Easy upgradeability
- Carrying both data and voice over PDH
- Easy integration to SDH network
- Higher reliability

Key Features

VCL-MX Version 6 – 80 E1, 160Mbps Multiplexer provides the advanced features and capabilities, listed below:

- 160Mbps, 80 E1 fully non-blocking cross-connect at 64Kbps (DS-0) level (2480 DS-0 – any to any time-slot cross-connect)
- Multi-service platform – may be used to provide a wide variety of voice and data services from single chassis
- 1+1 E1 Link Protection / E1 Port Redundancy
- 1+1 Control Card Processor Redundancy
- 1+1 Cross-Connect Redundancy
- 1+1 Timing (Synchronization Clock) Redundancy. User selectable synchronization priority.
- 1+1 48V DC Power Supply Redundancy (Dual Power Input – allows the equipment to be powered from two separate sources)
- 144 FXO or 144 FXS channels per unit.
- 72 E&M 2-wire / 4-wire channels per unit
- Any “mix” of data and voice channels in a single unit
- Universal Slots – slot independent system so that any type of interface card may be inserted and used in any card slot.
- Supports R2 CAS, ITU-T Q.421 and ITU-T Q.422 signaling
- Supports CAS Custom / User Programmable ABCD Signaling
- Bit Error Rate (BER) monitoring – BER thresholds to generate BER alarms automatically whenever alarm limits are exceeded.
- Supports Long Loops of up to 1200 Ohms
- Supports 75 VRMS and 90 VRSM Ring Voltage Options
- Supports A-law and Mu-law voice coding.
- Supports sinusoidal un-balanced ring output
- Provides a ring of ≥ 75 volts RMS into a load of 5 R.E.N. on each channel with a 0.30 Erlang traffic pattern (5 R.E.N. load = 5 parallel phone load on each line).
- May be used in a Point-to-Point, Point-to-Multi point, Add-Drop (drop-insert), Tree and Star topology
- Telnet
- SSH for secured access
- SNMP traps
- Maintains Access Security Log
- In-band and Out-of-band management
- GUI (Graphical User Interface)

Additional Features

- Voice and Digital Data services
- Any combination (“mix-n-match”) of Voice and Digital Data services deployed from a single VCL-MX “Smart Shelf” - 4, 8, 12, 16 channels per card
- Integrated IEEE C37.94 Teleprotection Interface
- Digital Data option may be used for internet access or video conferencing application
- Wireless applications including Cellular Networks
- Digital Microwave Radio
- SCADA applications
- ATM/Frame Relay circuit termination
- Powerful Network Management System for monitoring and network control
- Compliance with all relevant ITU-T (CCITT) recommendations
- 19-inch, 6U high construction.

Highlights

- Field upgradable to provide voice, data or both services
- Flexibility on use of transmission medium-copper, fiber or wireless
- Choice of Interfaces for Voice and Data Applications
- USB and RS232, Interface for local connection through the serial interface to the "Network Control and Management Software"
- In-band and Out-of-band system configuration and management interface.
- Channel assignment independent of slot position in the sub-rack
- Extensive set of alarms
- User Selectable Internal, External and Loop-timed clock synchronization priority options
- Universal slots - any interface card can plug in at any interface slot.
- OAM Card

Security and Password Features:

System Access, Control and Management Options:

- Telnet
- SSH
- CLI Control Interface (HyperTerminal or VT100)
- SNMP V2 Traps (MIB File provided).

OAM: Operation And Management Ports

- RS232 Serial Port
- USB COM Port
- 10/100BaseT Ethernet for remote access.

Security and Protection

- Secured Access via SSH V2
- Password Protection: Password Protection in compliance with the mandatory clauses of the GR-815-CORE-2 specifications for secured access control.
- Logging: Maintains a log of all successful and un-successful attempts. Logged information includes the ID and the IP address of the accessing entities. Alerts the administrator if the un-successful logging attempts exceed 3.
- Security Audit: All access logs for up to 30 days are maintained for security audit purposes.
- Security log entry of any request or activity including that user-ID (including IP address, if applicable), to establish user accountability
- Report Generation / Audit Trail
- Security Administration.

Transmission Mediums

The VCL-MX offers an excellent flexibility on the choice of transmission medium over which it may be deployed. The transmission medium can be either of the following:

- Copper
- Optical Fiber
- Wireless.

Multi-service platform

VCL-MX Version 6 - E1 160Mbps Multiplexer supports both data and voice traffic.

For voice traffic, it supports the following interfaces:

- FXO
- FXS
- E&M (2Wire / 4Wire)
- Hot-Line (Ring-Down)
- Ring Generator (75V RMS)
- 15-Way Conference
- Magneto (GEN-GEN)
- BRI ISDN (2B+D).

For data traffic, it supports the following interfaces:

- Channelized E1 / Fractional E1 data
- RS-232 asynchronous data
- V.24 synchronous data / asynchronous data
- G.703, @ 64 Kbps, co-directional
- V.35, V.36, X.21, V.11, RS530, RS449 synchronous, "n"x64Kbps data
- 10/100BaseT - Ethernet Bridge (Optical and Electrical)
- Analog I/O Card (Dry Contact)
- Digital I/O Card (TTL signal)
- Universal DCE / DTE synchronous "n"x64Kbps data interface
- 8E1 plus 100Mbps Ethernet fiber optical transport interface along with the following:
 - EOW (Engineering Order Wire) channel for end to end installation and maintenance
 - Local and remote loop back test for diagnostics
 - 1+1 Fiber Path protection
 - ALS (Auto Laser Shutdown) facility for eye safety
 - 10/100M Ethernet Port - 100 Mbps Ethernet data transmission rate complies with IEEE8 02.3
- BRI ISDN (2B+D).

Configuration and Flexibility

VCL-MX Version 6 - E1 160Mbps Multiplexer can be configured as an Add-Drop Multiplexer (ADM) and Terminal Multiplexer (TMUX). It can support diverse topologies like point-to-point, ring, star and tree.

It can be configured in various topologies supporting both electrical and optical interfaces. It can take modular cards, which would enable the customers to start small and grow as traffic demands scale.

Synchronization

Timing Options	Internal Clock, Loop-Timed Clock, External Clock. User selectable synchronization priority
Synchronization Sources	Internal Clock, span clock timing derived from incoming HDB3 links (Loop-Timed), External Clock, 75 Ohms (TTL), 2.048 Mbits and 120 Ohms (Bits clock)
Default Option	Internal Clock (Stratum 3)

Application of VCL-MX

POTS (voice), digital data or real-time video conferencing services (V.35, V.36, X.21, 10BaseT Ethernet Bridge) high-speed digital data interface options allow point-to-point network solutions for providing a video conferencing channel of up to 1920 Kbps).

- Junction Mux - for digital interconnection of analog exchanges
- Point-to-Point, Point-to-Multi point, Add-Drop (drop-insert), Tree and Star topology applications
- Wireless network applications
- High-speed data ports for digital communication links providing Leased Lines access to Internet Service Providers (ISPs) with speeds ranging from 64Kbps up to 1920 Kbps digital data interface options
- Micro-Cellular infrastructure applications for providing cell-switch connectivity
- Wide area networking
- Internet access over POTS lines - All POTS interfaces operate @ 64Kbps and support V.34 (33.6Kbps) dial-up modems.

System Overview and Architectural Details

The VCL-MX Version 6 – 80 E1, 160Mbps Multiplexer provides full range of POTS (voice) and digital data services to subscribers located at different locations, requiring to interconnect and establish a voice and data network over an E1 Link. The VCL-MX is a simple, yet powerful E1 Channel Bank for connecting and integrating analog communication equipment with digital E1 services.

The VCL-MX Version 6 – 80 E1 160Mbps Multiplexer provides cross connect, voice telephony and digital data services for applications, which may include:

E1 Multiplexer platform has been envisaged to address the growing demand for an ultra-compact Add-Drop Multiplexer (ADM) and provide Ethernet-over-PDH mapping functions. It can be configured in various topologies such as linear, star, ring and bus.

VCL-MX Version 6 – 80 E1, 160Mbps Multiplexer has a multi-slot chassis with TDM backplane. In the chassis, there are ten (10) traffic slots meant for tributary cards (line cards). The line cards can support various type of interface cards, which include E1, Voice and very wide variety of Data interfaces.

Two slots are reserved for 1+1 redundant system / control cards, which include the redundant cross connect, processor and aggregate interface functions. One dedicated slot exists for an OAM card, one for ring generation and two slots for 1+1 redundant power supply.

Safety: Laser protection

The optical interfaces of the VCL-MX Version 6 - E1 160Mbps Multiplexer come with Class 1, Small Form-factor Pluggable (SFP)-based optical line interfaces with digital diagnostics capability for SFPs on the optical interface cards.

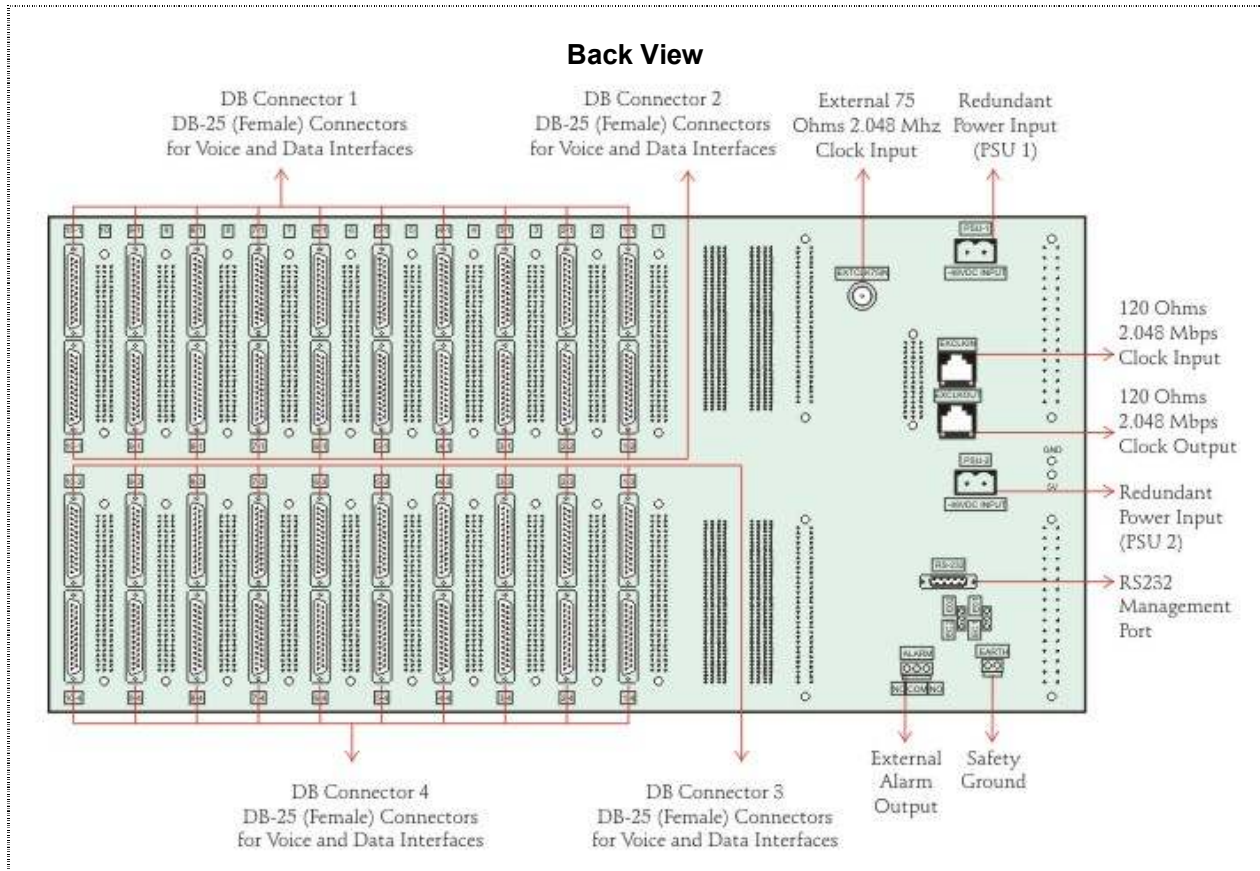

The Multiplexer may be used in Terminal or Drop-Insert configuration to provide:

- Toll Quality Voice Services
- Interconnect LAN (Campus Network)
- Interconnect computer terminals various types of data terminals
- Provide LAN-WAN Interconnectivity.

Voice Interfaces

For voice traffic, it supports the following interfaces:

- FXO
- FXS
- E&M (2-wire and 4-wire)
- Hot-Line (Ring-Down)
- Ring Generator (75V RMS)
- 15-Way, Multi-port voice conference capability, allows up to 5 user groups or a maximum 15 voice channels to set up multi port voice conferencing. Station calling is selective using DTMF dialing.
- Magneto (GEN-GEN)
- BRI ISDN (2B+D)

Data Interfaces

For data traffic, it supports the following interfaces:

- Channelized E1 / Fractional E1 data with full cross-connect capability at 64Kbps, DS-0 level
- RS-232 asynchronous data
- V.24 synchronous data / asynchronous data
- G.703, @ 64 Kbps, co-directional
- V.35, V.36, X.21, V.11, RS530, RS449 synchronous, "n"x64Kbps data
- 10/100BaseT - Ethernet Bridge (Optical and Electrical)
- Analog I/O Card (Dry Contact)
- Digital I/O Card (TTL signal)
- IEEE C37.94 Teleprotection Interface
- Universal DCE/DTE synchronous "n"x64Kbps data interface
- 8E1 plus 100Mbps Ethernet fiber optical (1+1) protected transport interface

Chassis / System Backplane

All connections are made at the rear of the chassis, providing interconnections between the various plug-in cards and to the network. VCL-MX Version 6 - E1 160Mbps Multiplexer and supports high-density PDH cards. The line cards terminate a combination of Voice, Data and E1 Interfaces.

The VCL-MX E1 Multiplexer has a 160 MBits/sec backplane and provides a host of features including, channel drop and insert facility over a network of VCL-MX E1 Multiplexers, for voice and data applications.

An extensive set of alarms, for easy maintenance are provided in the system.

System Management

VCL-MX Version # 6 - Voice and Data Drop-Insert Multiplexer offer a variety of management options, The VCL-MX E1 multiplexer management software can be configured using CLI (English text) commands and GUI (Graphical User Interface). The management and configuration commands may be executed from a VT100 terminal, Windows HyperTerminal, any DOS based system, Linux or UNIX based system, or Telnet (remote management).

The equipment provides a wide choice of access ports for connecting to and executing management and configuration commands through its OAM Card

The OAM card provides:

- a) COM Port (RS232 Serial Port).
- b) USB Port
- c) 10/100BaseT Ethernet Port (each multiplexer may be assigned an IP address and connected to a LAN / IP network for remote access and management through the 10/100BaseT Ethernet Port for out-of-band configuration, management and access).
- d) Telnet
- e) SSH
- f) SNMP, V2
- g) Additionally, a Windows based GUI (Graphical User Interface) for easy configuration, management and access.

The VCL-MX has an effective, CLI (text) and GUI based "Network Management Interface", which may be used for configuring and monitoring multiple systems from a single central location.

Technical Specifications:**E1 Interface: (Part No. VCL-MX-1520)**

Maximum number of interface cards (in a single chassis)	As per requirement and upto 10 Used to map with Voice and Data Interface
Number of interfaces per E1 Interface Card	8 E1 Interfaces
Conformity (electrical)	G.703
Frame structure	As per ITU (CCITT) G.704
Signaling	Channel Associated Signaling)
PCM Sampling Rate	8000 Samples / sec
Bit rate	2048 Kbps \pm 50 ppm
Code	HDB3, 50 % Duty Cycle
Nominal Impedance	120 Ω balanced / 75 Ω unbalanced
Peak voltage of a mark For 120 Ω Balanced interface 75 Ω Unbalanced interface	3.0 V \pm 0.3 V 2.37 V \pm 0.237 V
Peak voltage of a space For 120 Ω Balanced interface 75 Ω Unbalanced interface	0 V \pm 0.3 V 0 V \pm 0.237 V
Nominal pulse width	244 ns
Pulse mask	As per ITU (CCITT) Rec. G.703
Output jitter	<0.05 UI (in the frequency range of 20Hz to 100 KHz)
Permissible Attenuation	6 dB at 1 MHz
Return loss at: 51.2 KHz to 102.4 KHz 102.4 KHz to 2048 KHz 2048 KHz to 3072 KHz	>12dB > 18dB > 14dB
Jitter tolerance	As per ITU (CCITT) G.823
Frame alignment	As per ITU (CCITT) G.732
Loss and recovery of frame alignment	As per clause 3 of ITU (CCITT) G.732
Loss and recovery of multi-frame alignment	As per clause 5.2 of ITU (CCITT) G.732

FXS, Voice Frequency Interface: (Part No. VCL-MX-1525-FXS)

Maximum number of interface cards	9
Number of channels per card	16
Interface type	FXS, A-law, 8 bit/sample, A=87.6 / 87.7, 13 segment coding
Maximum number of channels (In a single chassis)	144
Transmission performance	Fully compliant to ITU (CCITT) G.712 specification
Line impedance	600Ω (900Ω optional)
Voice channel frequency	300Hz-3400Hz
Insertion loss / gain	-2.0 dB Nominal (user adjustable) Adjustable range -30 dB to +3 dB in steps of 0.5dB
User selectable range for gain / insertion loss	0 dB to 18 dB
Idle channel noise	≤ - 65 dB
Return loss	300Hz – 600Hz - ≥ 12 dB 600Hz – 3400Hz - ≥ 15 dB
Longitudinal balance	≥ 46 dB between 300Hz to 3400Hz
Ring frequency	16 Hz, 20 Hz, 25 Hz, 50 Hz
Ring voltage	≥ 75 volts RMS into a load of 5 R.E.N. with a 0.30 Erlang traffic pattern
Subscriber loop current	≥ 23mA into a subscriber loop of 1000 Ohms
Overload level	+3.14 dBm ± 0.5 dBm
Battery reversal	All channels
Dial pulse speed	50 pps - Pulse Dialing ≤ ± 2 ms / DTMF Dialing

FXO, Voice Frequency Interface: (Part No. VCL-MX-1530-FXO)

Maximum number of interface cards	9
Number of channels per card	16
Interface type	FXO A-law, 8 bit/sample, A=87.6 / 87.7, 13 segment coding
Maximum number of channels (In a single chassis)	144
Transmission performance	Fully compliant to ITU (CCITT) G.712 specification
Line impedance	600Ω (900Ω optional)
Voice channel frequency	300Hz-3400Hz
Insertion Loss / Gain	-2.0 dB Nominal (user adjustable) Adjustable range -30 dB to +3 dB in steps of 0.5 dB
User selectable range for gain / insertion loss	0 dB to 18 dB
Idle Channel Noise	≤ -65dB
Return loss	300Hz - 600Hz - ≥ 12 dB 600Hz - 3400Hz - ≥ 15 dB
Longitudinal balance	≥ 46 dB between 300Hz to 3400Hz
Overload Level	+3.14 dBm ± 0.5 dBm

Battery reversal	All channels
Dial pulse speed	50 pps - Pulse Dialing $\leq \pm 2$ ms / DTMF Dialing

Hot-Line Interface Card: (Part No. VCL-MX-1525-HTL)

Number of channels per card	4 / 8 / 12 / 16
Interface type	Hot-Line A-law, 8 bit/sample, A=87.6 / 87.7, 13 segment coding
Maximum number of channels	144
Transmission performance	Fully compliant to ITU (CCITT) G.712 specification
Line Impedance	600 Ω (900 Ω optional)
Loop resistance	Upto 2000 Ohms
Voice channel frequency	300Hz-3400Hz
Insertion loss / gain	-2.0 dB Nominal (user adjustable) Adjustable range -30 dB to +3 dB in steps of 0.5 dB
User selectable range for gain / insertion loss	0 dB to 18 dB
Idle channel noise	≤ -65 dB
Return loss	300Hz - 600Hz - ≥ 12 dB 600Hz - 3400Hz - ≥ 15 dB
Longitudinal balance	≥ 46 dB between 300Hz to 3400Hz
Ring frequency	16 Hz, 20 Hz , 25 Hz, 50 Hz
Ring voltage	≥ 75 volts RMS into a load of 5 R.E.N. with a 0.30 Erlang traffic pattern
Subscriber loop current	≥ 23 mA into a subscriber loop of 1000 Ohms
Overload level	+3.14 dBm \pm 0.5 dBm
Dialing	Ring-down

E&M 2 Wire / 4 Wire Voice Frequency Interface (Part No. VCL-MX-1535)

Number of channels per card	4 / 8
Interface type	2W / 4W E&M, Type II and Type V A-law, 8 bit/sample, A=87.6 / 87.7, 13 segment coding
Maximum number of channels	72
Transmission performance	Fully compliant to ITU (CCITT) G.712 specifications
Line impedance	600 Ω (900 Ω optional)
Voice channel frequency	300Hz-3400Hz
Insertion loss / gain	-2.0 dB Nominal (user adjustable) Adjustable range -30 dB to +7 dB in steps of 0.5 dB
User selectable range for gain / insertion loss	0 dB to 18 dB
Idle channel noise	≤ 65 dB
Return loss	300Hz - 600Hz - ≥ 12 dB 600Hz - 3400Hz - ≥ 15 dB
Longitudinal balance	≥ 46 dB between 300Hz to 3400Hz

Dial pulse speed	50 pps - Pulse Dialing $\leq \pm 2$ ms / DTMF Dialing
Maximum M-Lead resistance	1200 Ohms
Maximum M-Lead current drain	≤ 5 mA
Maximum E-Lead current	≤ 100 mA

Conference Interface Card: (Part No. VCL-MX-1590)

Number of channels per card	4 / 8 / 12 / 16
Conference capability	15-Way, Multiport voice conference capability, allows up to 5 user groups or a maximum 15 voice channels to set up multi port voice conferencing. Station calling is selective using DTMF dialing.
Interface type	15-way voice conference card A-law, 8 bit/sample, A=87.6 / 87.7, 13 segment coding
Maximum number of channels	144
Transmission performance	Fully compliant to ITU (CCITT) G.712 specification
Line impedance	600 Ω
Voice channel frequency	300Hz-3400Hz
Insertion Loss / Gain	-2.0 dB Nominal (user adjustable) Adjustable range -30 dB to +3 dB
User selectable range for gain / insertion loss	0 dB to 18 dB
Idle channel noise	≤ 65 dB
Return loss	300Hz - 600Hz - ≥ 12 dB 600Hz - 3400Hz - ≥ 15 dB
Longitudinal balance	≥ 46 dB between 300Hz to 3400Hz
Ring frequency	16 Hz, 20 Hz, 25 Hz, 50 Hz
Ring voltage	≥ 75 volts RMS into a load of 5 R.E.N. with a 0.30 Erlang traffic pattern
Subscriber loop current	≥ 23 mA into a subscriber loop of 1000 Ohms
Overload level	+3.14dBm \pm 0.5dBm
Dialing	DTMF Dialing

GEN GEN / Magneto Interface Card: (Part No. VCL-MX-1587)

Number of channels per card	16
Interface type	Magneto, 2-wire (GEN-GEN) A-law, 8 bit/sample, A=87.6 / 87.7, 13 segment coding
Line impedance	600 Ω
Voice channel frequency	300Hz-3400Hz
Ring generator frequency	16 Hz, 20 Hz, 25 Hz, 50 Hz
Ring voltage	≥ 75 volts RMS
Maximum number of channels	144
Transmission performance	Fully Compliant to ITU (CCITT) G.712 specification

Voice channel frequency	300Hz-3400Hz
Insertion loss / gain	-2.0 dB Nominal (user adjustable) Adjustable range -30dB to +3 dB
User selectable range for gain / insertion loss	0 dB to 18 dB
Idle channel noise	≤ -65 dB
Return loss	300Hz - 600Hz - ≥ 12dB 600Hz - 3400Hz - ≥ 15dB
Longitudinal balance	≥ 46 dB between 300Hz to 3400Hz
Overload level	+3.14 dBm ± 0.5 dBm

Low Speed Data Interface Asynchronous RS232 (Part No. VCL-MX-1559)

Number of interfaces per card	4 / 8
Maximum number of interfaces	9
Conformity	RS232 (V.24/V.28 line drivers)
Mode	Asynchronous
Bit rate	50 bps to 19.2 Kbps
User interface	DCE
Character length	5 / 6 / 7 / 8 (auto-select)
Stop bits	1 / 1.5 / 2 (auto-select)
Parity	Even / Odd / 0's / 1's / none (auto-select)

64Kbps Data Interface (Part No. VCL-MX-1545)

Interface	V.35 / V.36 / X.21 / RS232 / RS530 / RS485 / V.11 / V.28
Number of interfaces per card	4
Maximum number of interfaces	9
Conformity	To CCITT Rec. V.35
Mode	Synchronous DCE
Bit rate	64 Kbps

G.703 @ 64kbps, Synchronous Data Interface: (Part No. VCL-MX-1560)

Interface	G.703 @ 64 Kbps
Number of interfaces per card	4 / 8
Maximum number of interfaces	72
Conformity	To (CCITT) Rec. G.703
Mode	Synchronous, Co-directional
Bit rate	64Kbps
Protection	As per ITU-T Rec. K.20

Low Speed Data Interface Card V.24 Sync / Async: (Part No. VCL-MX-1546)

Number of Interface per card	4
Maximum number of interfaces	36
Conformity	To CCITT Rec. V.24
Mode	synchronous / asynchronous / DTE / DCE
For asynchronous interface	
Baud rate	50 / 75 / 110 / 134.5 / 150 / 200 / 300 / 600 / 1200 / 1800 / 2400 / 4800 / 7200 / 9600 / 19200 bps
Parity	Even / Odd / None
Character length	6 / 7 / 8
Stop bits	1, 2
For synchronous Interface	
Data Rate	600 / 1200 / 2400 / 4800 / 9600 / 19200 bps
Transmit clock source	Interface Clock (Clock derived from the V.24 Interface Card)
Receive clock source	Interface Clock (Clock derived from the V.24 Interface Card)

Digital I/O Interface Card: (Part No. VCL-MX-1548)

Description: This interface card provides 8 digital I/Os which may be used to either extend digital I/O's (logic high/low) signals between any two E1 Multiplexers or operate switches remotely (using logic high/low) signals between any two multiplexers. Drivers/Sense Logic operates using External Voltage and Ground references).

Digital I/O's - Type I

Number of interface per card	16
Digital drivers (current source type)	8
Max source current	100 mA
External reference voltage range	5 Volts to 30 Volts DC
External reference Voltage	Required
Minimum Load Resistance @ 5V	50R
Minimum Load Resistance @ 30V	300R
Digital sensor (current sink type)	8
Maximum sink current	20mA
Voltage range	5 Volts
External ground reference	Required
Isolation	≥ 2.5 kV

OR

Digital I/Os - Type II

Number of Interface per card	16
Digital drivers (current sink type)	8
Maximum sink current	100mA
Voltage range	5 Volts to 30 Volts DC
External ground reference	Required
Digital sensor (current source type)	8
Maximum sink current	30mA
Voltage range	5 Volts to 30 Volts DC
External ground reference	Required
Isolation	≥ 2.5 kV

Analog I/O Interface Card: (Part No. VCL-MX-1547)

Description: This interface card provides 8 Analog I/Os that may be used to extend either Dry Relay Contacts (Relay Normally-Open or Relay Normally-Close) or operate switches remotely (using Dry Relay Contacts rated 2A @ 30Volts DC) between any two Multiplexers using a 64 Kbps time-slot.

Relay Specifications (Drivers)

Maximum number of relay ports	8 / 16
Maximum switching power	60 W (approximately)
Maximum switching voltage / current	60V DC, 2 A 250V AC, 2 A
Isolation	2.5 KVA Minimum
Typical number of operations	> 1 million

Dry Contacts Sensors

Maximum number of dry contact sensors	8 / 16
Maximum current	50 mA
Typical current	20 mA
Reference source voltage	3.3 Volts

BRI ISDN 2B+D: (Part No. VCL-MX-1550)

"U" interface	Meets ANSI T1.601-1992 requirements
Line rate	160 Kbits/s
Frame format	2B+D as per CCITT Rec.1.430
Line code	2B1Q as per CCITT Rec.G.961
Accepted line attenuation	42dB at 40 KHz
Pulse shape	As per CCITT Rec.G.961
Multiplexer emulation	LT Emulation/NT Emulation (user selectable)
Impedance	135 Ohms at 40KHz

Maximum distance: 5 km (4 miles) on 0.5 mm twisted Pan. Distance may vary with cable gauge. For distance using various cable gauges please refer chart below.

Maximum Permissible Distance in kms. (miles) for BRI ISDN links				
Data Rate (Kbps)	Wire Gauge (AWG/mm)			
	19 (.9mm)	22 (.6mm)	24 (.5mm)	26 (.4mm)
160	17.4 (10.8)	11.6 (7.2)	8.1 (5.0)	5.5 (3.4)

Universal Data Interface: High Speed Synchronous "n x 64" Data Interface Type - User Configurable DCE-DTE: (Part No. VCL-MX-1558)

Interface	V.35 (DTE/DCE) V.36 (DTE/DCE) X.21 (DTE/DCE) V.11 (DTE/DCE) RS442 (DTE/DCE) RS530 (DTE/DCE)
Number of interfaces per card	4, ("N" x 64KBits/sec. per card)
Bandwidth	("N" x 64 Kbits/sec. interface maximum value of "N" =30)-user selectable
Conformity	Universal user-configurable as above
Mode	Synchronous
Bit rate	64 Kbps to 1920 Kbps
User interface	DCE/DTE (User programmable for DTE/DCE mode)

High Speed “n x 64” Data Interface Type: 10/100BaseT Ethernet with both Electrical and Optical Ethernet options: (Part No. VCL-MX-1595)

Interface	10/100BaseT (Electrical / Optical)
Total number of interfaces per card	4 (3, 10/100BaseT Electrical and 1, 100FX Optical Port)
Application	Point to point
Bandwidth	(“N” x 64 Kbits/sec. interface minimum value of “N” =1 maximum value of “N” =248) - user selectable
Aggregate bandwidth	16Mbps - maximum
Conformity	10/100BaseT Ethernet Electrical / Optical
Mode	Synchronous
Bit rate	64 Kbps to 16Mbps
User interface	10/100BaseT

8 E1 Plus 100Mbps Ethernet Fiber Optical Transport Interface (Part No. VCL-MX-1551)

Optical	
Number of optical ports	1+1 redundant, automatic link protection
Channel capacity	8E1 Plus 100Mbps Ethernet
Jitter character	ITU-T G.742, G.823 compliant
Type of transmitter	Class 1 Laser
Transmitter power	-11 dBm to +3 dBm - as ordered 20 km, 40 km, 80 km, 120 km reach – as ordered
Receive sensitivity	- 34 dBm
Bit rate	155 Mbps
Wavelength	850 nm multimode / 1310nm singlemode / 1550nm singlemode (optional)
Optical connector	LC (MSA Compliant SFP Module)
Fully compliant with ITU-T G.957, G.958 Specification	
Class 1 Laser Product, Compliant with IEC 60825-1	
Compliant with Telcordia (Bellcore) GR-468-CORE	
Safety	
Class 1 Laser	
Auto Laser Shut Down in the event of fiber break.	
Ethernet Interface - 10/100BaseT	
Number of interfaces	4
Interface	RJ-45 Ethernet 10BaseT or 100BaseT-TX (auto sensing)
Compliance	Ethernet Version 2.0 IEEE802.3 10Base-T & 100Base-TX Activity, Full/half duplex.
Interface rate	100 Mbps Ethernet data transmission rate

Order Wire Interface	
Phone set	Standard 2-wire phone set
Bandwidth and coding	64 Kb/s PCM Channel, A-Law Coding

Integrated IEEE C37.94 Teleprotection Interface (Part No. VCL-MX-1552)

Number of ports	4
Standards	IEEE C37.94
Optical	850nm Multi Mode (2KM) 1310nm Multi Mode (2KM) 1310nm Single Mode (40KM / 80KM / 120KM)
Optical connector	FC / PC
Safety	Class 1 Laser

Protection

Remote / FXS (subscriber side) interface is protected against power surges and transients occurring from lightning and electric induction as per ITU-T Rec. K.20 towards line side.

Management Interface

<ul style="list-style-type: none"> COM Port (RS232 Serial Port)
<ul style="list-style-type: none"> USB Port
<ul style="list-style-type: none"> 10/100BaseT Ethernet Port - Each multiplexer may be assigned an IP address and connected to a LAN / IP network for remote access and management through the 10BaseT Ethernet Port for out-of-band configuration, management and access
<ul style="list-style-type: none"> Telnet
<ul style="list-style-type: none"> SSH
<ul style="list-style-type: none"> SNMP, V2
<ul style="list-style-type: none"> Windows based GUI (Graphical User Interface) for easy configuration, management and access.

Power Supply

Input DC Voltage	-48V DC (nominal)
Range of Input	-36V to -72V DC
Output Voltage	5V filtered -48V (for terminal cards)
Full Load Current	4A at 48V DC
Input Voltage Reversal Protection	Provided in the Card
Over Current Protection	6A at 48V DC
Short Circuit Protection	Current limit – 6A. Recovers on removal of short
Efficiency at Full Load	>91%
Ripple at Full Load	<5mVrms
Spike at Full Load	<50mV

Power Consumption

Maximum Power Consumption	≤ 200 watts
---------------------------	-------------

Environmental

Temperature	-10°C to + 60°C
Humidity	95% R.H. (non-condensing)
Altitude	Upto 9,000 feet

Dimensions

Height	266 mm (19 " 6U high)
Width	482 mm
Depth	270 mm
Weight	12 Kgs.

Applications

The VCL-MX Version 6 - E1 160Mbps Multiplexer can be configured in Linear and Bus architectures. It can be used in the core of the network to provide high-speed backbone network.

The VCL-MX Version 6 - E1 160Mbps Multiplexer could provide the core for cellular or mobile networks between Mobile Switching Centers with subtended.

VCL-MX Version 6 - E1 160Mbps Multiplexer could also be used to provide versatile cross-connect functionality to connect telephone exchanges in VCL-MX Version 6 - E1 Multiplexer in dense metro areas.

Telco Networks Providing Voice and Data Services

VCL-MX Version 6 - E1 160Mbps Multiplexer is an ideal platform to provide high-end data and voice requirement of clients. VCL-MX Version 6 - E1 160Mbps Multiplexer can be installed at the regional and gateway Points of Presence (POP) locations in order to cater to the ever-growing data requirements of the customers while supporting legacy services at the same time.

The advantage that the VCL-MX Version 6 - E1 160Mbps Multiplexer provides the Telecom Service provider is as follows:

- The VCL-MX Version 6 - E1 160Mbps Multiplexer enables network simplifications by collapsing networks, nodes and services into a single multi service device. A smaller number of higher-density nodes and node types enable cost savings as a result of a smaller, more homogenous network to manage.
- The flexible architecture of the VCL-MX Version 6 - E1 160Mbps Multiplexer series ensures that the network is future proof, and the service provider has the flexibility of choosing a technology he thinks useful at any time in the future with minimal investment.

Application Diagram

Application 1: Providing Voice and Data Services on Microwave Radio Links

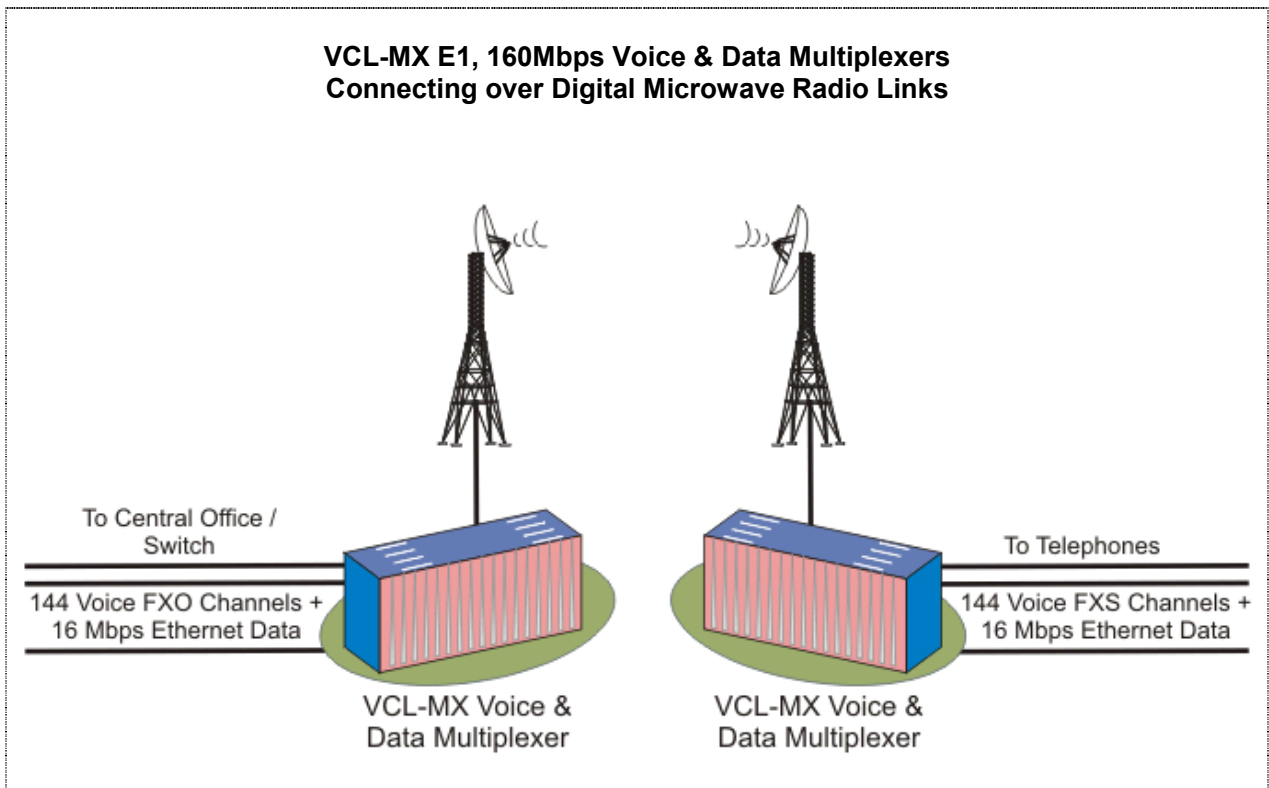

Application 2: Providing Voice and Data Services on Optical Fiber

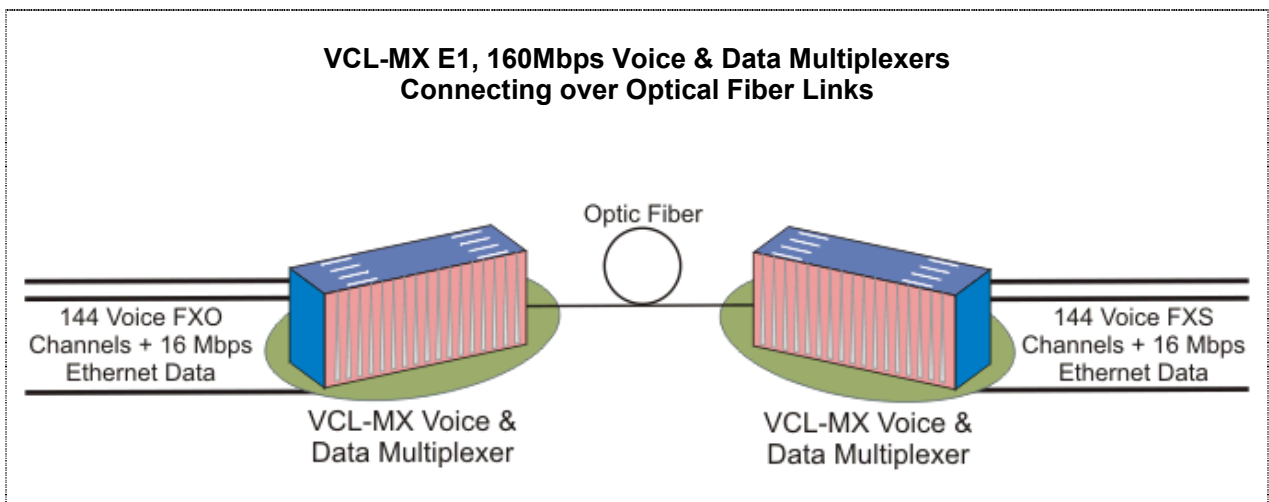

Application 3: Transporting E & M Channels

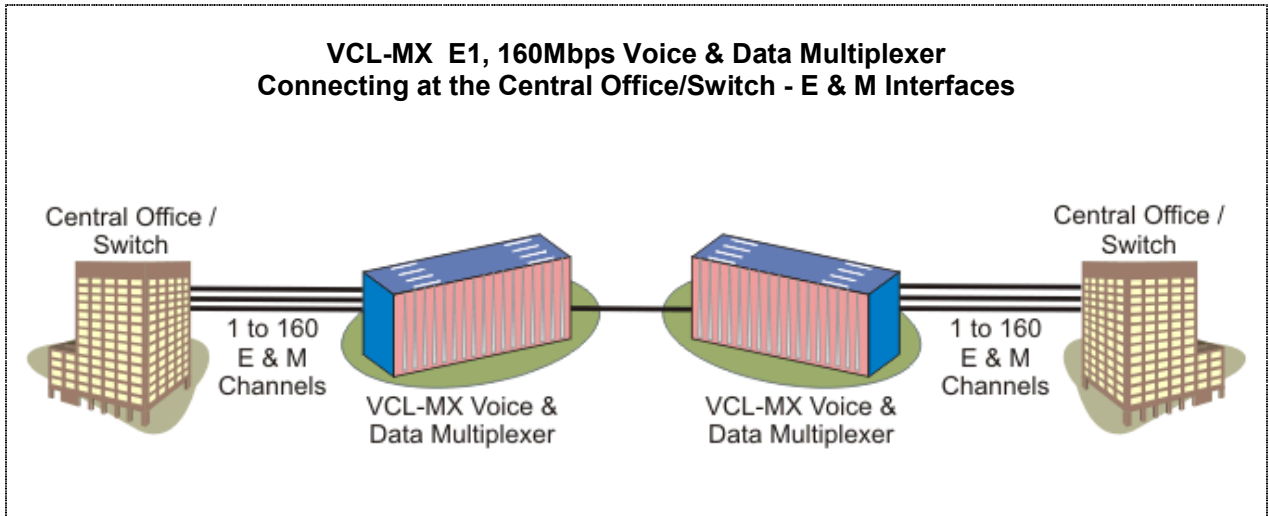

Application 4

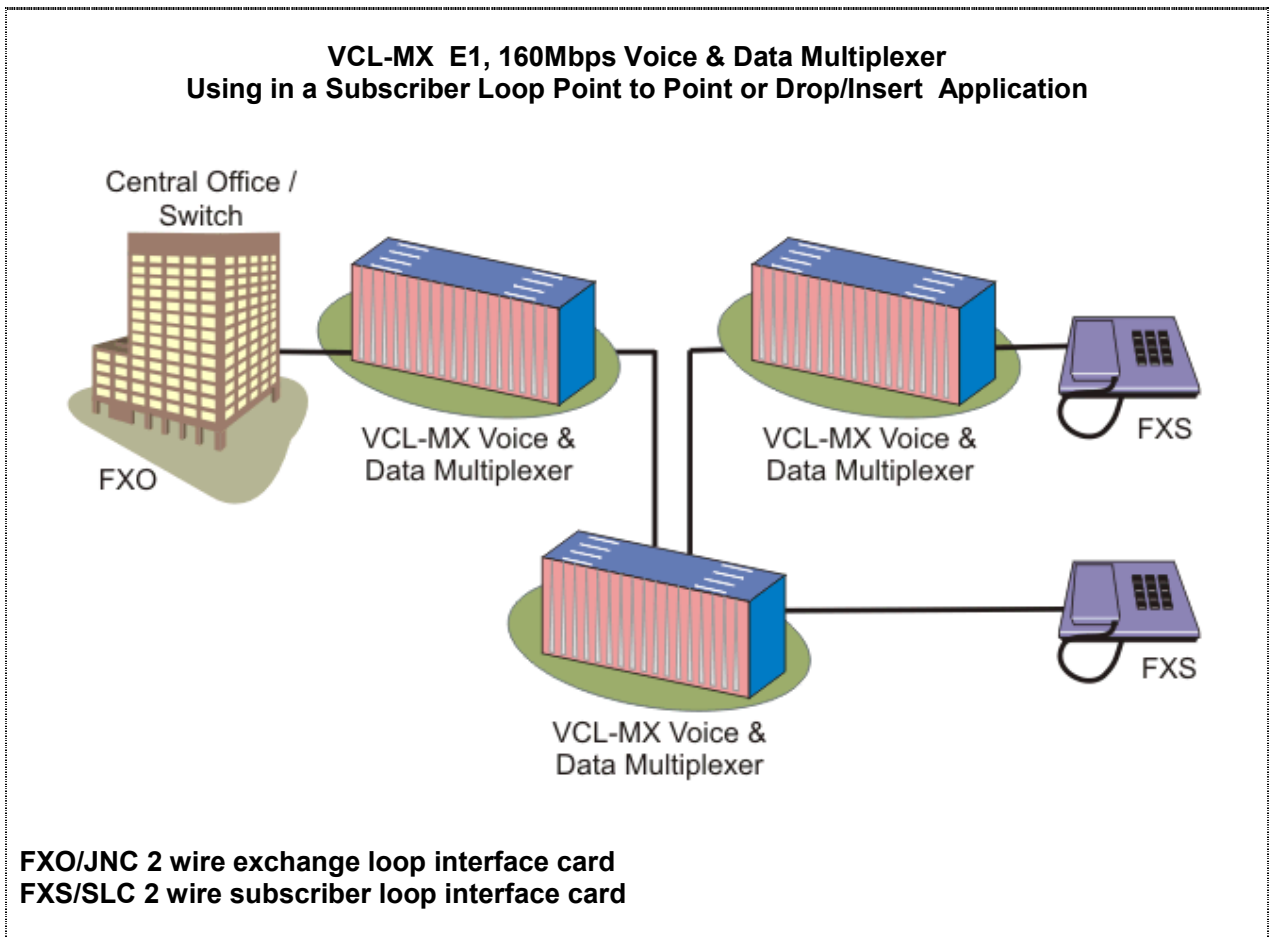

Application 5: Providing Synchronous “n x 64” Kbps Data Interfaces

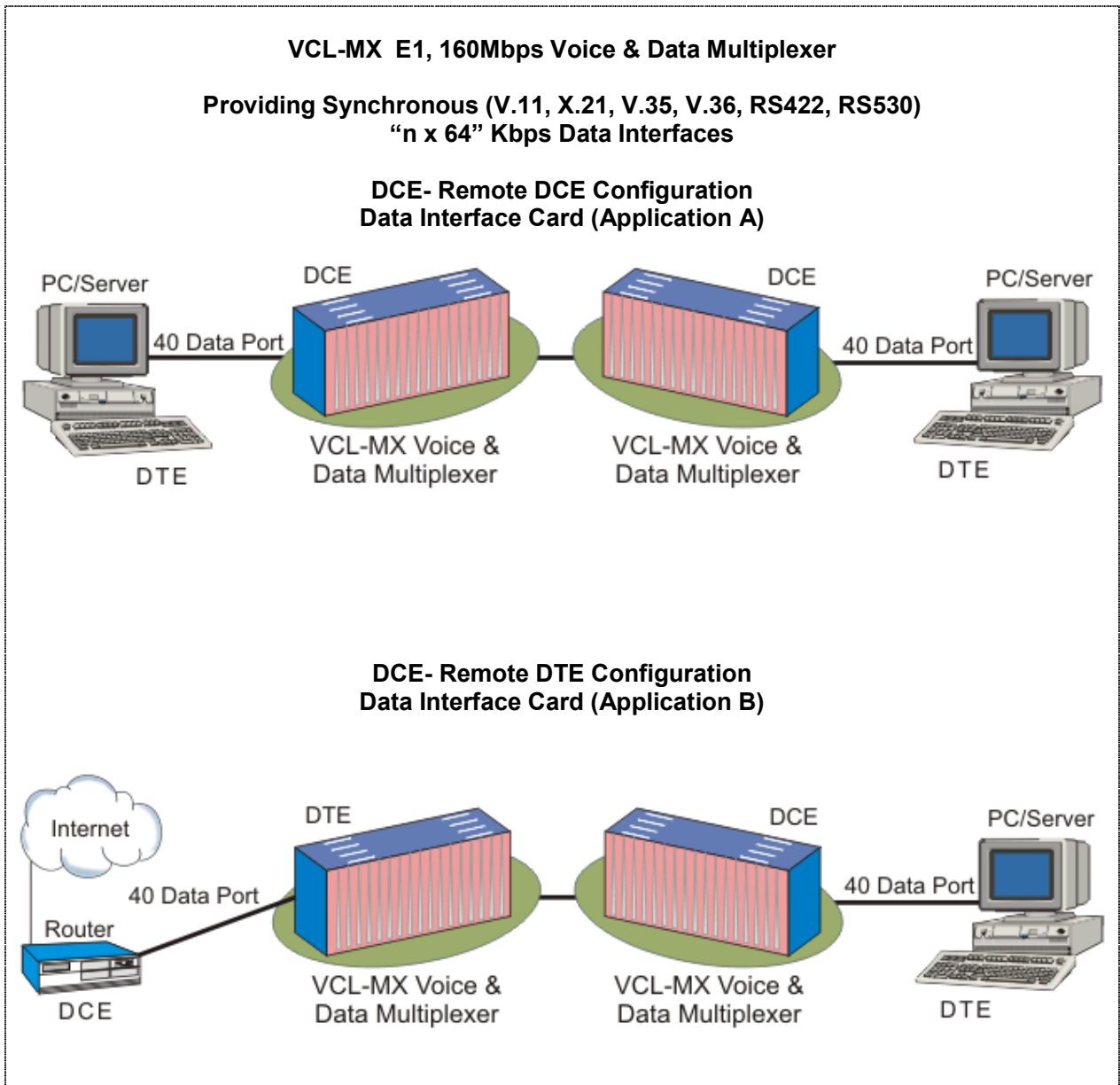

Application 6: Providing Voice and Synchronous “n x 64” Kbps Data Interfaces

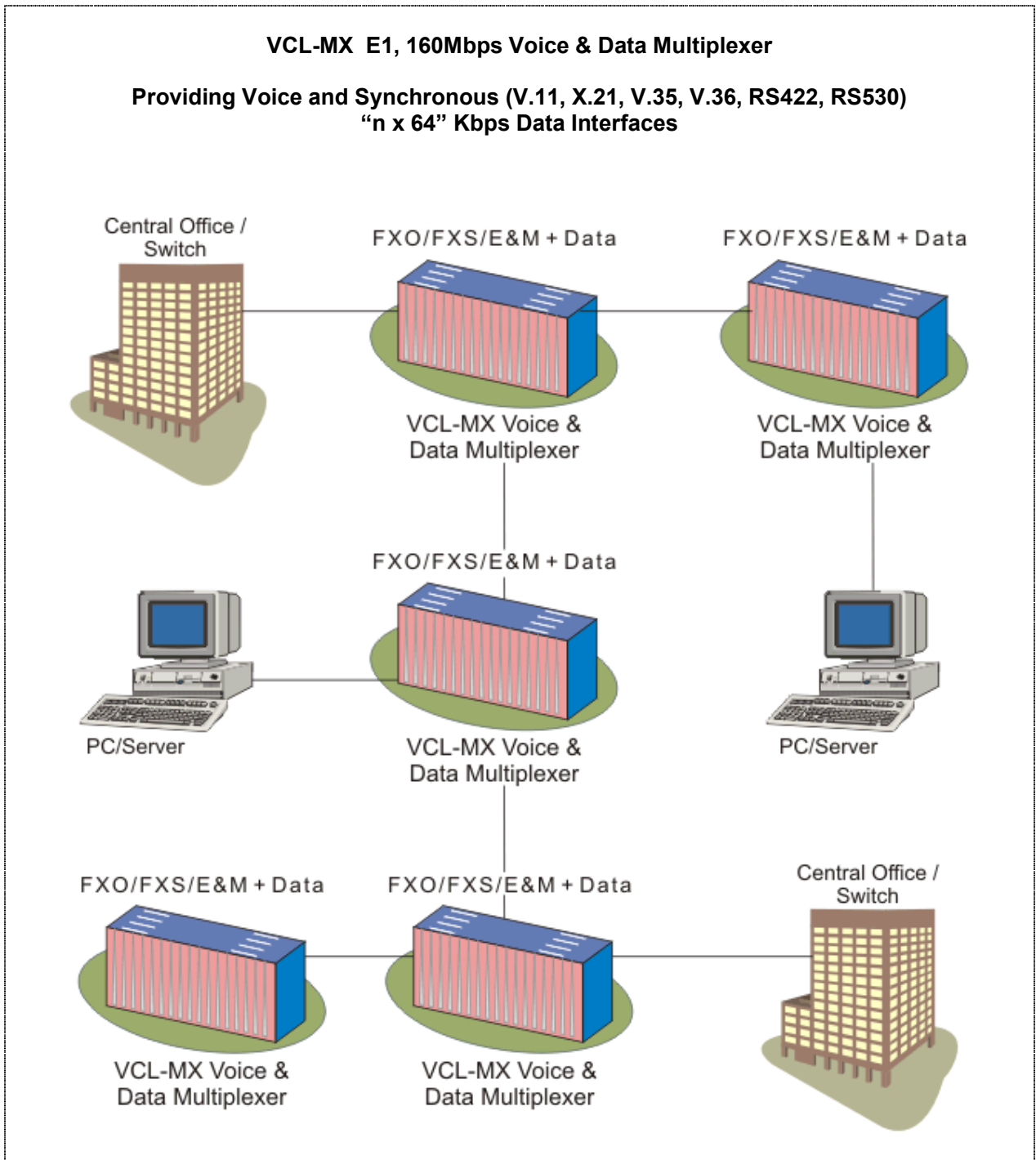

Application 7: For providing Hybrid Voice and Data Services

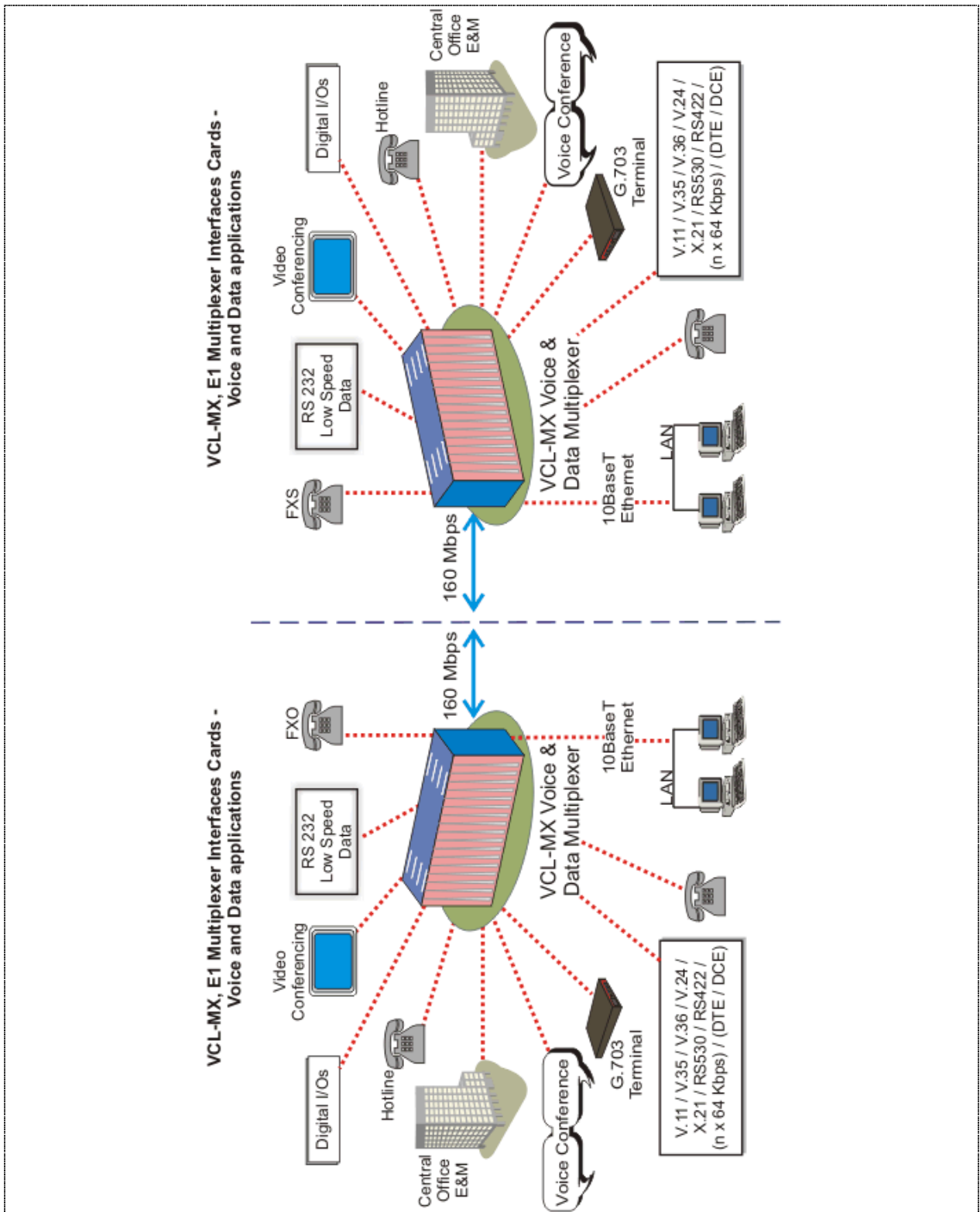

Application 8:

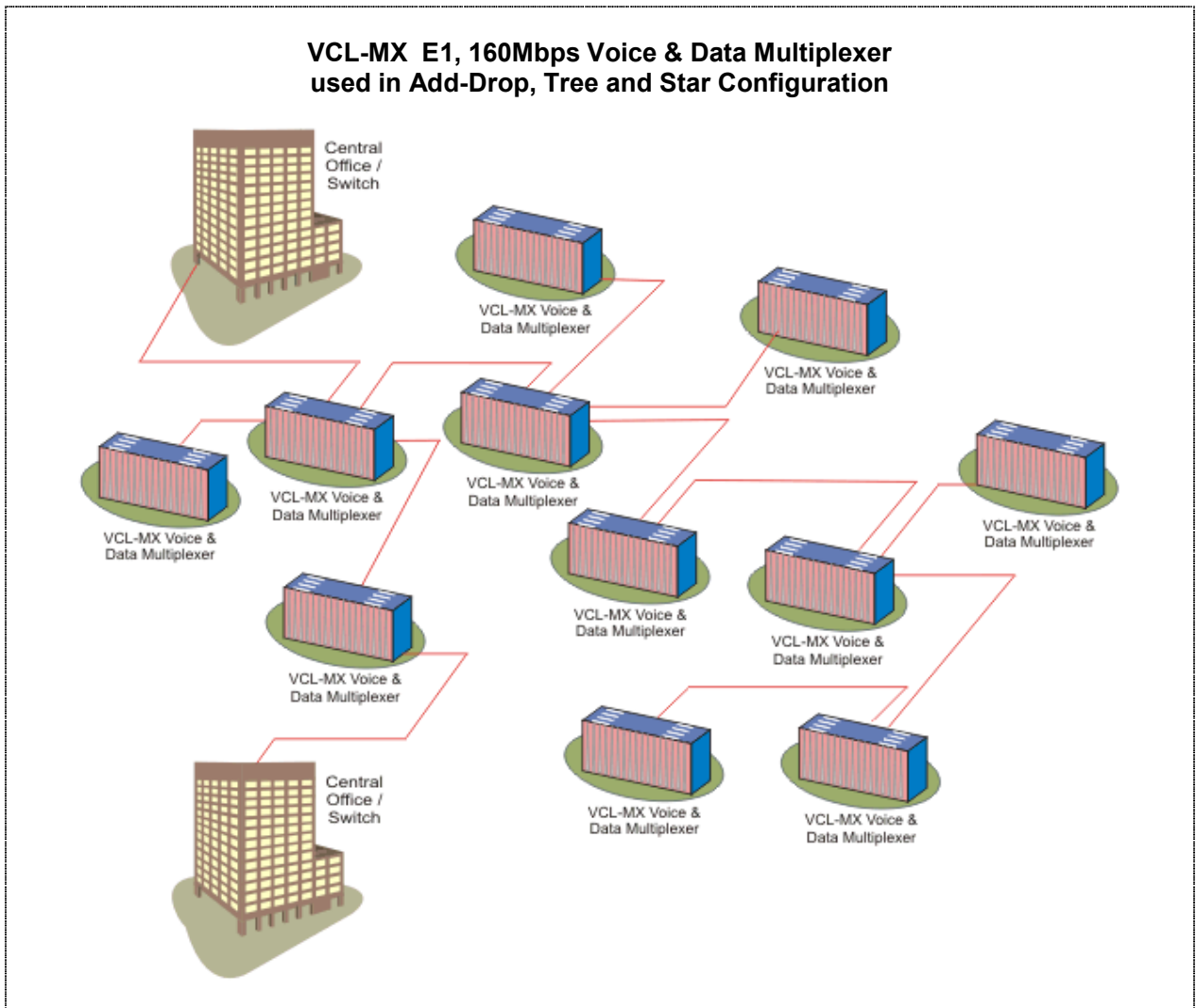

Ordering Information**VCL-MX E1 Core System (Common Equipment)**

S. No.	Part #	Product Description
1.	VCL-MX-1500	Control Card Central processor, cross-connect and system control Card may be used in a 1 + 1 redundant Configuration Note: Please order 2 numbers for 1 + 1 redundancy
2.	VCL-OAM-1490-5.0	Management Card [SNMP_USB] OAM - Operations and Management Card for connecting the multiplexer to be managed in a LAN - allows the USER to assign a unique IP address to each multiplexer connected in a LAN to be managed from a single point. Telnet, SNMP (V2)
3.	VCL-MX-1506	19" Shelf 6U High (Sub-rack) with Connectorized Backplane Max. Ten (10) traffic slots meant for tributary cards (line cards)
4.	VCL-MX-1510	(-) 48VDC Input Power Supply Card may be used in a 1 + 1 redundant Configuration Note: Please order 2 numbers for 1 + 1 redundancy
5.	Manual	Documentation User Manual & System Software Disks
6.	Installation Kit	VCL-MX Version-6 Installation Kit, includes: RS232 and USB serial Management Cables, Ethernet Management Cable, Hardware Set, Power Cables

VCL-MX, User Configurable Interfaces

S. No.	Part #	Product Description
1.	VCL-MX-1520-E1-5.0	8 E1 Interface Card Full capability to cross connect at DS-0, 64Kbps time-slot level as well as to inter-connect to voice and digital data services between 80 incoming E1 Ports (i.e., 80 separate E1 Links, 2480 DS-0 – any to any time-slot cross-connect). (For 8E1 Redundancy please order 2 Cards each Chassis)
2.	VCL-MX-1525-16-5.0	16 Port VF, RT (FXS) Line Interface Card 64Kbps/Sec. VF Channels per Remote Terminal Line Card. (Programmable Tx and Rx settings / VF range -30 dB to +3dB in steps of 0.5dB). (9 Cards / 144 Ports (Max) per Chassis)
3.	VCL-MX-1525HTL-16-5.0	16 Port VF, Hot-Line (FXS-Ring-Down) Line Interface Card: , 64Kbps/Sec. Hot-Line Channels per Card. (Programmable Tx and Rx settings / VF range -30 dB to +3dB in steps of 0.5 dB) (9 Cards / 144 Ports (Max) per Chassis)

4.	VCL-MX-1530-16-5.0	16 Port VF, CO (FXO) Line Interface Card 64Kbps/Sec. VF Channels per Central Office Line Card. (Programmable Tx and Rx settings / VF range -30 dB to +3dB in steps of 0.5 dB) (9 Cards / 144 Ports (Max) per Chassis)
5.	VCL-MX-1535-08-5.0	8 Port, VF, E&M 2 Wire / 4 Wire Interface Card 64Kbps/Sec. (Programmable Tx and Rx settings / VF range -30 dB to +7dB in steps of 0.5 dB) (09 cards / 72 Ports (Max) per Chassis)
6.	VCL-MX-1540-15	Ring Generator Card (15 Watt) Central Office Ring Generator (75 volts RMS). [Supports up to 4 x 16 Port VF, FXS Cards] (To be ordered with FXS card (s) - one card per Chassis)
7.	VCL-MX-1540-30	Ring Generator Card (30 Watt) Central Office Ring Generator Card (75 volts RMS). [Supports up to 9 x 16 Port VF, FXS Cards] (To be ordered with FXS card (s) - one card per Chassis)
8.	VCL-MX-1545-04-48	4 Port, 64Kbps DCE [V.35 or V.36 or X.21 or RS530 or V.11 or V.28] Synchronous OR [RS232 or RS485] Asynchronous Data Interface Card (9 Cards / 36 Ports (Max) per Chassis)
9.	VCL-MX-1547-16-48	16 Port, Analog I/O Interface Card [Extend either Dry Relay Contacts (Relay Normally-Open or Relay Normally-Close) or operate switches remotely (using Dry Relay Contacts rated 2A @ 30Volts DC) between any two Multiplexers using a 64 Kbps time-slot] (9 Cards / 72 Ports (Max) per Chassis)
10.	VCL-MX-1548-16-48	16 Port, Digital I/O Interface Card [Extend digital I/O's (logic high/low) signals between any two E1 Multiplexers or operate switches remotely (using logic high/low) signals between any two multiplexers. Drivers/Sense Logic operates using External Voltage and Ground references] (9 Cards / 72 Ports (Max) per Chassis)
11.	VCL-MX-1558-04-48	4 Port, "n x 64" High Speed 64 Kbps to 1920 Kbps (User Configurable) DCE/DTE Synchronous Universal Data Interface Card [DCE/DTE (User programmable for DTE/DCE mode)] [V.35, V.36, X.21, V.11, RS442, RS530] (9 Cards / 36 Ports (Max) per Chassis)
12.	VCL-MX-1559-08-5.0	8 Port, RS232 (V.24/V.28 Line Drivers) 50bps to 19.2Kbps DCE Asynchronous Data Interface Card (9 Cards / 72 Ports (Max) per Chassis)
13.	VCL-MX-1560-08	8 Port G.703 @ 64Kbps, Synchronous Co-directional Data Interface Card (9 Cards / 72 Ports (Max) per Chassis)

14.	VCL-MX-1551-5.0-WLWL-DKM	8 E1 Plus 100Mbps 4 Ethernet (Electrical RJ45F) over Fiber Optical Transport Interface Card [2 x SFP based / without SFPs] [WLWL = SFP Wavelength 0850, 1310 or 1550 in nm, DKM = SFP Distance in Km, 002, 015, 040, 080, 120, 150, 200, 260] [SFPs to be ordered separately] (9 Cards / 72 Ports (Max) per Chassis)
15.	VCL-MX-1595-5.0-4RJ45	1 x 100Mbps 4 Port Ethernet Card [Electrical RJ45F] Synchronous, User configurable from 64 Kbps to 16Mbps. User Selectable Data Transfer Rate (Max. bandwidth per card 16Mbps.) (9 Cards / 36 Ports (Max) per Chassis)
16.	VCL-MX-1595-5.0-WLWL-DKM	1 x 100Mbps 4 Port Ethernet Card [3 x Electrical RJ45F and 1 Optical Port SFP based/without SFP] Synchronous, User configurable from 64 Kbps to 16Mbps. User Selectable Data Transfer Rate (Max. bandwidth per card 16Mbps.) [WLWL = SFP Wavelength 0850, 1310 or 1550 in nm, DKM = SFP Distance in Km, 002, 015, 040, 080, 120, 150, 200, 260] [SFP to be ordered separately] (9 Cards / 36 Ports (Max) per Chassis)
17.	VCL-MX-1552-SM	4 Port, Integrated IEEE C37.94 Optical Interface, Duplex FC, 20KM, Single-Mode 1310nm (SM) Teleprotection Interface Card. Each 4-Port Interface card can be used to connect to upto 4, VCL-TP Teleprotection Terminals.
18.	VCL-MX-1552-MM	4 Port, Integrated IEEE C37.94 Optical Interface, Duplex FC, 2KM, Multi-Mode (MM) Teleprotection Interface Card. Each 4-Port Interface card can be used to connect to upto 4, VCL-TP Teleprotection Terminals.

<p>19.</p>	<p>VCL-TP-1531</p>	<p>VCL-TeleProtection Terminal Equipment</p> <p>19-Inch, 2U High Rack mountable Version [Core Equipment]</p> <ul style="list-style-type: none"> - Supports upto 8, 2-way independent-simultaneous command channels which may be configured to operate selectively or simultaneously over C37.94 Optical Fiber Interface, or 64Kbps PCM co-directional digital data Interface, or 2.048Mbps E1 digital data interface - OAM Card [10/100BaseT Ethernet - RJ45 (SNMP, Telnet and SSH) and Serial Port (USB and DB-9 COM Port)] - System Core Cables, Installation Accessories, Documentation, System User Manual etc (Set) - Graphical User Interface (GUI) and Network Management Software (NMS) - Command Voltages: 48V DC, 120V DC or 250V DC (factory set option, order any one) - Switching Voltages: 48V DC, 125V DC or 250V DC <p>Network Interfaces</p> <ul style="list-style-type: none"> - 1532 G.703 @ 64Kbps co-directional interface [1 (max) per system] OR - 1533-SM Optical - 2M , Duplex FC, 20Km, 1310nm, Single-Mode (SM) [1 (max) per system] OR - 1533-MM Optical -2M , Duplex FC, 2Km, 1310nm, Multi-Mode (MM) [1 (max) per system] <p>PSU Options</p> <ul style="list-style-type: none"> - DC110 1 x 110/125V DC Power Supply Input [60-160V DC] OR - DC048 1 x -48V DC Power Supply Input [18V-75V DC] OR - DC110R 2 x 110/125V DC Power Supply Input [60-160V DC] [Redundant - 1+1] OR - DC048R 2 x -48V DC Power Supply Input [18V-75V DC] [Redundant - 1+1]
------------	--------------------	---

Optional and Accessories

S. No.	Part #	Product Description
1.	VCL-MX-01048 19-RK	Power Supply (External) AC to DC Converter External Converter Universal AC Input [93V AC-276V AC, 47Hz-63Hz] to DC Output [(-) 48V DC]
2.	Cables	Connectorized Cables for FXS/FXO Cards (3 meters, DB25 to Open) - 2 cables per 16 port card and 1 cables per 8 port card
3.	Cables	E&M Connectorized Cables (3 meters, DB25 to Open) - 2 cables per 4 port card
4.	Cables	Connectorized Cables for RS232 Async. Cards (3 meters, DB25 to Open OR DB25 to DB25). Please clarify. - 2 cables per 8 port card
5.	Cables	Connectorized Cables for G.703 Cards (3 meters, DB25 to Open OR DB25 to RJ-45). Please clarify. - 2 cables per 8 port card
6.	Cables	Connectorized Cables for AIO Cards (3 meters, DB25 to Open) - 4 cables per 16 port card
7.	Cables	Ethernet Connectorized Cables (3 meters, DB25 to RJ-45) - 4 cables per 4 port card
8.	Cables	V.35 (M34 - Winchester) - "n" x 64Kbps Connectorized Cable (3 meters, DB25 to Winchester) - 4 cables per 4 port card
9.	Cables	V.36/X.21/RS530/V.11 - "n" x 64Kbps Connectorized Cable (3 meters, DB25 to DB25) - 4 cables per 4 port card
10.	Cables	E1 Interface - Connectorized Cables (3 meters, DB25 to Open) - 2 cables per 8 port card
11.	VCL-1505-TER-DB37F-RJ45F-16PP	16xE1, DB37 [2 x DB37F] to RJ45 [16 x RJ45F] Termination Panel [1x1505T01] 19" Metal case 1U High Rack Mount Version with Hardware Set
12.	Cables	E1 Interface - DB-37(M) to 2 x DB-25(M) Cable - 1 Cable per E1 card
13.	Blank-Plate 6U	6U high blank plates to cover un-used slots
14.	Blank-Plate 3U	3U high blank plates to cover un-used slots
15.	VCL-1513/1514-TER-DB37F-BNCF-8PP	16 x E1, DB-37 [2xDB37F] to BNC [16xBNCF] 75 Ohms Termination Panel [1x1513T01 and 1514T00]. 19" Metal case 1U High Rack Mount Version

Note: -----

Technical specifications are subjects to changes without notice.
Revision 3.3 – April 25, 2012.

INDIA

Valiant Communications Limited

71/1, Shivaji Marg, New Delhi - 110015, India
Phone: +91-11 4105 5601, +91-11 4105 5602,
+91-11 4105 5603, +91-11 2592 8415,
Fax: +91-11 4105 5604, +91-11 2543 4300
E-mail: getinfo@valiantcom.com
Website: http://www.valiantcom.com

U.S.A.

Valcomm Technologies Inc.

4000 Ponce de Leon, Suite 470
Coral Gables, FL 33146
United States of America
E-mail: fl@valiantcom.com
Website: http://www.valiantcom.com

U.K.

Valiant Communications (UK) Ltd

1, Acton Hill Mews, 310-328 Uxbridge Road,
London W3 9QN
United Kingdom
E-mail: uk@valiantcom.com
Website: http://www.valiantcom.com